



Integrated Waste Management System with IOT-Based Centralized Control towards a Smart Eco Campus-Telkom University

Agus Ganda Permana¹, Jangkung Raharjo^{2*}

¹School of Applied Science, Telkom University, Bandung, Indonesia, ²School of Electrical Engineering, Telkom University, Bandung, Indonesia. *Email: jangkungraharjo@telkomuniversity.ac.id

Received: 10 November 2022

Accepted: 22 February 2023

DOI: <https://doi.org/10.32479/ijeeep.14048>

ABSTRACT

Telkom University is a private university in Indonesia that has implemented an eco-campus or green campus program. The Greenmetric Program is one part of Telkom University's strategic planning in realizing a campus that cares and has an environmental culture by managing the environment in a systematic and sustainable manner. One of the programs is to reduce waste production. Therefore, it is necessary to conduct research related to optimizing waste management by implementing Onsite Waste Treatment Technology-Integrated-Independent-Environmentally Friendly (TOSS-TMRL). TOSS-TMRL Management System with Centralized Control Based on the Internet of Things (IoT) Towards a Smart ECO Campus to be completed on the spot. This will reduce pollution, operational costs, and waste management investment and can even function as Living Labs for environmental-based courses. In addition, optimization is also one of the efforts to realize a smart eco campus towards the best-ranking Green Metric Telkom University. Wireless communication technology is very efficient, effective, and easy to use. One of the applications can be applied to determine the condition of environmental cleanliness in a campus area by integrating microcontroller technology and detection devices (sensors, QR codes, AR/imaging, and CCTV) with Wireless Sensor Networks (WSN) and IoT applications as tools to increase awareness of the importance of sorting waste so that the cleanliness of the campus area can be maintained. In this study, a system and network architecture design were carried out based on the number of sensor nodes, the number of recycle bins, the number of garbage transportation equipment, the number of buildings, the number of areas, and the ability of Data Transfer Nodes (DTN) to provide information to the server taken from the recycle bin of each room/building, business areas, SME facilities, canteens, and dormitories or local areas. With this system, it is hoped that there will be no accumulation of garbage and allow users/garbage managers to interact with the system through a web browser and android application.

Keywords: Waste Management, TOSS-TMRL, IoT, Smart Eco Campus

JEL Classifications: Q2, Q28, Q5, Q55, Q56

1. INTRODUCTION

In recent years, the issue of environmental conservation has become an important global issue that is systematic, complicated, complex, and has a fairly broad scope (Bretschger and Pittel, 2020). This problem is the main concern of various programs implemented by the government, private sector, and non-governmental organizations (Maund et al., 2018), (Ferronato and Torretta, 2019). However, in practice, this problem is still not

optimally resolved, so it takes a principle and action that can guide human activities towards development, especially development in terms of environmental conservation. The path that can be used to channel principles, values, actions, and social responsibility is through education (Short, 2009), (Slavoljub et al., 2015).

One type of educational institution that can directly apply in practice is a higher education institution. The level of education at the university or campus is considered to have the potential

and an important role in answering various problems, including environmental issues (Findler et al., 2019), (Jadhav et al., 2014). The recent environmental program is aimed at developing and realizing environmental conservation efforts through the concept of an environmentally friendly campus area or eco campus (Zerin et al., 2017), (Finlay and Massey, 2012).

The eco campus concept is a management concept developed by the institutional community to create a green and environmentally friendly campus environment by prioritizing conservation, savings (reduce, reuse, recycle), and good, healthy, and environmentally friendly handling (Gandasari et al., 2020). Higher education institutions that have implemented the eco-campus concept can be identified by accessing it through the information held by UI GreenMetric (Kusumaningtyas et al., 2019).

UI Green Metric is an international-scale competition that assesses universities in terms of their real contribution to environmental conservation or as a benchmark (rating system) to rank the sustainability efforts of campuses in the world with certain index numbers and methodologies Universitas Indonesia (UI) Green Metrics, 2015. There are six categories of green campus/eco campus assessments in the Green Metric, namely setting and infrastructure, energy, and climate change, waste, water, transportation, and education. According to UI GreenMetric data in 2015, there are several universities in Indonesia that have implemented smart eco campuses and received Green Metric ratings and awards.

Eco campus or green campus is a sustainable environmental management system that is applied at the higher education level. All campus residents and the surrounding community can participate in environmental conservation programs, including the education system, and community service research. The utilization of existing resources effectively and efficiently has a positive impact on the environment, economy, and society.

Institut Teknologi Sepuluh Nopember (ITS) Smart Eco Campus implements improving the efficiency of clean water use and improving water quality, increasing energy efficiency, integrated waste management, developing environmentally friendly transportation tools, and protecting biodiversity. The increasing number of environmental challenges leads to increased public consciousness of nature. Individuals and communities are starting to implement sustainable green environmental practices that can increase efficiency and economic well-being. In addition, it also provides direct benefits for environmental health and public welfare (Hermana et al., 2018).

Telkom University has started to develop and build environmentally buildings with the green campus concept since 2015. This seriousness is shown by participating in the UI GreenMetric assessment, in 2015. Telkom University was ranked 212th in the world ranking as a green campus in the UI Green Metric World University assessment (Greenmetric, 2017).

In 2016 Telkom University continued to show efforts to create a green campus or green campus within the Telkom University

environment. Evidence shows the increasing implementation of green campuses at Telkom University with the increase in the ranking of Telkom University in the UI GreenMetric WorldUniversity assessment in 2016 to 172, an increase in the previous year, namely 2015 at rank 212 (Greenmetric, 2017).

The assessment criteria used in the 2018 UI Green Metric World University include Setting and Infrastructure (SI), Energy and Climate Change (EC), Waste (WS), Water (WR), Transportation (TR), and Education and Research (ED). The assessment parameters used in UI Green Metric World University 2018 include Setting and Infrastructure (SI), Energy and Climate Change (EC), Waste (WS), Water (WR), Transportation (TR), and Education and Research (ED). While the weight of the assessment is SI (15%), EC (21%), WS (18%), WR (10%), TR (18%), and ED (18%) (Greenmetric, 2017).

Specifically, the Waste (WS) indicator must be maintained properly and even improved because it is very supportive of other categories, namely WR, EC, and ED in obtaining Green Metric scores. Details of waste indicators can be seen in Table 1 (Greenmetric, 2017).

Putra et al., 2018 developed an incinerator as an energy generator by designing a valve control system using the fuzzy logic method. Another study by Zega et al. develops applications to control air pollution due to carbon monoxide, nitrogen oxides, and excessive sulfur dioxide from incinerator combustion (Zega et al., 2018). These previous studies strongly support the EC indicator, indicating that they greatly contribute to obtaining or getting a fairly large point from the EC category point (21%) due to energy-saving efforts, the creation of an integrated new renewable energy system, and minimizing the extreme climate change due to global warming. due to conventional waste incineration without appropriate treatment, environmentally friendly technology, and pollution from unpleasant odors and toxic gases due to piles of rotting garbage.

One of the efforts made by Telkom University in implementing a green campus is the establishment of the Gonigoni start-up. A system that connects waste management with the community. Gonigoni offers a complete waste management system by maximizing the function of waste recyclers and establishing a recycling chain using the right technology. The Waste Bank Program can reduce the accumulation of waste. Organic waste is processed, including processing leaf waste into fertilizer, for now, the results of waste management in the form of organic fertilizer are still used privately by the campus and have not been mass-produced for sale to external parties (Gonigoni, 2020).

Table 1: WS indicators

S. No.	Indicator
1	Recycling waste program in the university
2	Reducing the use of paper and plastic programs in campus
3	Biological waste management
4	Biological waste management
5	Handling toxic waste
6	Sewage removal

Gonigoni has a program that invites the public, communities, schools, and others to build a waste bank. Waste banks participating in the Gonicorner program will be supported by other programs, such as Gonicraft, Gonilibrary, etc. The output of this program will be included in Gonigoni events such as bazaars and recycling days (Gonigoni, 2020). The efforts above show performance on the ED criteria. In detail, the ED indicator can be seen in Table 2.

Based on this background, this paper discusses the Study on the Implementation of the Telkom University TOSS TMRL management system with centralized control based on the Internet of Things (IoT) towards a smart Eco Campus, which is expected to reduce and solve the problem of waste generation. The danger of infection with germs, bacteria, and viruses comes from special bins in shared spaces. In addition, it is hoped that the recycle bin/garbage cart/smart garbage transport vehicle will be one of the means to run programs that have been designed to maintain health and cleanliness in the campus environment. With the application of several devices such as the SRF 05 proximity sensor, IC L293D as a motor driver, limit switch, and dc motor, a device entity that is able to work properly helps the 3R process of waste, transport, and process waste in the TOSS TMRL area of Telkom University optimally.

2. MATERIALS AND METHODS

2.1. Waste Management

Waste management is needed starting from the place where the waste is located until the waste is disposed of at the final shelter. Waste management is a methodical, all-encompassing, and sustainable activity that involves handling, processing, and reducing waste. According to the goals outlined in Law No. 18 of 2008 concerning Waste Management, the central and regional governments are entrusted with guaranteeing the implementation of good waste management from an environmental standpoint.

Waste is essentially a material that is wasted from a source as a result of human activities or natural processes. It has no economic worth and may even have a negative economic value due to the high costs associated with processing it in order to either dispose of it or clean it. Waste is defined as material that has no value or is useless for basic or routine purposes in the production of damaged or defective commodities, as well as surplus, rejected, or discarded material.

Table 2: ED indicators

S. No.	Indicator
1	The proportion of sustainability courses to all other subjects and courses
2	The proportion of funding for research on sustainability to all research funds
3	Published scientific works on sustainability and the environment
4	Number of academic conferences on sustainability and the environment
5	Numerous student organizations focused on sustainability and the environment
6	Existence of a sustainability website run by a university
7	Publication of a sustainability report

Waste management systems available to households can significantly reduce the stages of waste collection and disposal. Utilization of household waste into a safe energy source without harmful emissions is produced biologically through composting or anaerobic digestion as well as physicochemical processes such as combustion or pyrolysis (Jouhara et al., 2017).

Due to its benefits in reducing garbage and recovering energy, municipal solid waste incineration (MSWI) has been widely used; nonetheless, MSWI fly ash and bottom ash constitute a threat to the environment and public health. The author reviews the production procedure, physical and chemical characteristics, leaching properties, pretreatment methods, and use of fly ash and bottom ash, which have a wide range of possible uses (Lu et al., 2020).

2.2. Garbage Processing Machine (GPM)

Garbage Processing Machine is a tool or machine to burn waste and process it by incineration using combustion technology that is designed in such a way with a certain temperature so that the residual combustion is very minimal. Incineration technology uses technology that converts solid material (in this case waste) into gaseous material (exhaust gas), as well as solid material that is difficult to burn, namely ash (bottom ash) and dust (fly ash) with the waste processing method by burning waste at a furnace. This tool can be equipped with a control system (by Burner) and control (by Termocontrol and Termocople) to meet the emission limits of particulate matter and exhaust gases so that the smoke that comes out of the trash incinerator is smoke/gas that is neutral (not just smokeless).

The ash produced from the combustion process can be used for building materials, made into a compost mixture, or disposed of in landfills. Meanwhile, residue from non-combustible waste such as metal scraps can be recycled. The incinerator uses a waste treatment process by burning at a temperature of 400-600°C, while for smoke burning/filtering a temperature between 400 and 1200°C is needed.

The incineration technology products mentioned above have been widely used in various cities in Indonesia, but the incinerators used are still not optimal, not only expensive because they cost up to billions of rupiah but also cannot answer all problems related to waste, the environment, operations, and maintenance. Generally, these tools are imported from abroad which cost billions of rupiahs and require trained and trained operators and technicians. The product of this external incineration technology in operation is quite expensive because the process of destroying waste requires a large amount of fuel and electricity continuously. In addition, tool components are not easily available in the domestic market, so it is quite inconvenient when there is damage and maintenance.

Smart GPM is a GPM with an integrated waste management module. The technical aspects of smart GPM are related to the process of developing portable and mobile waste processing machine systems which technical and operation are built according to Standard Operating Procedures (SOP). The Smart GPM product can answer the problems mentioned above, this garbage incinerator

is able to burn completely and run out of waste that goes into the garbage incinerator. Complete combustion is related to the amount of oxygen that enters the combustion chamber as well as the accuracy in carrying out the first combustion, the required heat of combustion, cheap O and M due to the use of EBT fuel and ICT control, as well as reducing combustion residues, even compact or integrated and independent.

2.3. Waste Material Balance Calculation

Calculation of campus waste material balance plays an important role in supporting the acquisition of performance (points) from the categories of Energy and climate change (EC) management, waste management (WS), and Education and Research (ED) which are based on collective and analysis of data on the amount of generation, composition and waste recycling potential and data on the number of campus communities in each area (Rectorate, Faculty, Dormitory, Business District, Canteen, Pasum, and others) Telkom University, the effectiveness of the existing management system, the impact caused by waste. The calculation includes the amount of waste generation based on the type, namely wet (organic) and dry (inorganic) waste, the amount of generation of each type of waste that can be recycled, and the amount of residual waste (residual) which will be assisted by an Internet of Things-based control and monitoring system so that optimal results were obtained in the waste management and processing process in the TOSS-TMRL area of Telkom University. The following is a description of the parameters that must be used as guidelines for the application of environmentally friendly waste processing machines using new and renewable energy in the TOSS-TMRL Swakelola, Telkom University of TOSS-TMRL Telkom University.

2.3.1. Garbage Generation

Garbage generation is the volume and weight of waste produced by a community in units of people per day, or the expansion of buildings or roadways (Badan Standarisasi Nasional, 2002). Additionally, waste generation is the volume of organic or inorganic garbage that is produced as a result of regular community activities. Garbage generation has different magnitudes in the area. The amount of waste can be divided into two, namely based on the city classification and the components of the waste source (Badan Standarisasi Nasional, 1995).

$$G = \frac{\alpha}{N} \quad (1)$$

Where α is a total waste of mass [kg]; N is the number of people [person/day]; G is garbage generation [$\frac{kg}{person/day}$]

The amount of waste transportation efficiency can be known by calculating the waste transportation efficiency index (IEP) (Hemidat et al., 2017).

$$IEP = \frac{AxT}{VxL} \quad (2)$$

Where A is the number of workers (persons); T is transport time (hours); V is carrying capacity (m^3 /rit); and L is the distance traveled (km).

$$Ct = \frac{Vxr}{Cx F} \quad (3)$$

Where Ct is the number of trash bins per cycle (garbage bin/rit); V is pick up capacity/motor viar/garbage cart (m^3 /garbage bin); r is density ratio = 1; C is capacity of garbage bin (m^3 /bin); and F is container weight utility factor = 0.67.

$$P = Ct x Ue + (Np - 1) Dbe \quad (4)$$

Where P is load time (hours/cycle); Ct is the number of empty trash bins per trip (garbage bin/cycle); Ue is the average time to make garbage to Pick Up/motor viar/garbage cart (hours/garbage bin); Np is number of trash bins per rit (tub/cycle); and Dbe : average time between trash bin locations (hours/locations).

$$T = P + S + a + bx \quad (5)$$

Where T is time per cycle (hour/cycle); S is waiting time per field = 0.1; a is travel time constant from the resident's trash bin to the waste bak (hours/cycle); b is travel time constant from TAK waste to TOSS TMRL (hours/mile); x is round-trip distance (miles/cycle).

$$Nd = \frac{(H(1-w) - (t_1 + t_2))}{T} \quad (6)$$

Where Nd is the number of cycles per day; H is the working hours of transportation equipment; w is the drag factor, expressed in percent + 15%; t_1 is the travel time from TOSS TMRL to the first garbage location (hours); t_2 is the travel time from the last garbage bin location to TOSS-TMRL (hours).

2.3.2. GPM Measurement

The performance parameters of the incinerator which are measured in the performance are determined based on the analysis of the performance of the tool. The incinerator work test analysis includes:

2.3.3. Temperature measurement

Incinerator combustion temperature measurement, temperature measurement is carried out directly in this study in an interval of time t , with a certain airflow, a certain amount and type of waste, and a certain fuel power and intake of LPG. Temperature measurement using a thermocouple with a maximum accuracy of 1200°C. (i) Combustion Time (minutes). The length of the burning time is determined according to the maximum capacity of the incinerator, namely 80, 90, 100, 110, and 120 min. (ii). Combustion Temperature (°C). The combustion temperature is determined according to the maximum capacity of the incinerator, namely 800°, 900°, 1000°, 1100°, and 1200°C.

2.3.4. Burn rate (Bbt)

The parameters measured for the analysis of the combustion rate are the mass of the waste and the duration of combustion. The combustion rate is calculated by comparing the weight of the burned waste with the length of in the combustion process. The formula for calculating the rate of combustion is shown in (7).

$$Bbt = \frac{m}{T} \tag{7}$$

Where *Bbt* is the burning rate; *m* is the mass of burnt waste; *T* is the burning time.

2.3.5. Charcoal yield

Charcoal yield is a parameter to find out the perfection of the combustion process. The parameters measured for the analysis of charcoal yield are the mass parameters of the charcoal produced by the combustion process and the mass of the burned waste. Charcoal yield value is calculated by the percentage ratio of the mass of charcoal and the mass of the waste.

$$\text{Charcoal yield (\%)} = \frac{\text{Charcoal mass}}{\text{waste mass}} \times 100\% \tag{8}$$

2.3.6. Ash yield

Ash yield is used to determine the perfection of the combustion process. The parameters measured by the ash yield analysis were the mass of ash produced by combustion and the mass of the waste. The ash yield value is calculated by the percentage ratio between the mass of ash and the mass of the waste.

$$\text{Ass yields (\%)} = \frac{\text{Ash mass}}{\text{Waste mass}} \times 100\% \tag{9}$$

2.3.7. Water discharge

Water discharge is the velocity of liquid flow per unit of time, it is necessary to ensure in order to determine the required water flow, we must first know the unit of measure for volume and unit of time because water discharge is closely related to the unit of volume and unit of time for the wet scrubber process, cooling system (circulation) and treatment and treatment of waste or residual water or leachate. Water discharge is volume divided by time.

2.3.8. Emission Load

The emission load itself is the total amount of a gas produced from activities that cause air pollution, where the emission load is expressed in tons/year (Suryati et al., 2018). Emissions can be generated from natural processes and human activities. Emissions are the main cause of air pollution. Open and closed burning of waste using incinerators causes air emissions. The mathematical equation to determine the emission load influenced by the emission factor which is the unit of emulsified pollutant per unit mass of the burned material is shown in (10).

$$EF = \frac{C \times Q_{obtf} \times T}{m} \tag{10}$$

Where *EF* is the emission factor (mg/kg waste burned); *AF* is the activity factor; *C* is the concentration of pollutant in the waste sample (mg/m³); *Q_{obtf}* is flowrate of dilution air into the open burning test facility in (m³/min); *T* is burning time (minutes). The activity factor is waste generation x total population x % burning of waste x frequency of garbage. Total Emission load (EL), based on U.S. EPA (2001) is stated by (11).

$$EL = FE \times TS \times JP \times PS \times FPS \times 365 \tag{11}$$

Where *EL* is the total emission load from pollutant × (tonnes/year); *FE* is the emission factor of pollutant × (g/kg); *TS* is the average waste generation in the study area (kg/person/day); *JP* is total population (persons) of the study area (%); *PS* is the percentage of population burning waste (%); *FPS*: frequency of waste burning (times/day).

2.3.9. GPM Emissions and Pollutant Quality Standards

GPM will produce flue gases. Disposal of flue gases through the chimney must go through a series of cleaning processes before being discharged into the ambient air. The main composition or content of flue gas that has not been processed (raw flue gases) in incinerators include SO₂, NO_x, CO, acid gas HF, HCl, particulates, heavy metals such as Hg, Cd, and some trace elements and Dioxins/Furans (PCDD/PCDF) as shown in Table 3.

2.3.10. Efficiency of GPM

The NPM efficiency (*ε*) is performed to find out how big the percentage of the tool is to reduce waste. If charcoal yield is *A* % and Ash yield is *B*%, then the GPM efficiency (*ε*) is expressed by (12).

$$\epsilon (\%) = 100\% - (A(\%) + B(\%)) \tag{12}$$

2.3.11. Environmentally Friendly Independent Integrated Local Waste Processing Site (TOSS-TMRL)

Onsite Waste Treatment Technology-Integrated-Independent-Environmentally Friendly (TOSS TMRL) is a method of handling waste management and processing completely at waste-producing sources so that it is useful and beneficial with an integrated self-management pattern based on EBT (New Renewable Energy) and ICT (Information and Communication and Technology) so that

Table 3: GPM (incinerator) emission quality standards

Parameter	Unit	Indonesia ¹	Malaysia ²	Singapore ²	Japan ²	Europe ³
SO ₂	mg/N. m ³	210	50	500	varied	50
NO _x	mg/N. m ³	470	200	700	335	200
HCl	mg/N. m ³	10	40	40	700	10
CO	mg/N. m ³	625	50	625	125	50
Particulate	mg/N. m ³	120	100	100	40	10
Dioxin	Ng-TEQ/N m ³	0.1	0.1	0.1	0.1	0.1
LOI bottom ash	% dry weight	-	-	-	5	5

¹Peraturan Menteri Lingkungan Hidup & Kehutanan No. 70, 2016 (Regulation of Minister of Environment, & Forestry Republic of Indonesia No. 70, 2016).

²Damanhuri, 2016 available at <https://opac.perpusnas.go.id/DetailOpac.aspx?id=1011416>.

³European Directive (2000/76/EC), available at <https://www.legislation.gov.uk/eudr/2000/76/contents>

the operation is safe, easy, efficient with emissions that meet the requirements of the Decree of the Minister of the Environment No. 13/ MENLH/3/1995. The TOSS-TMRL area is described as follows:

1. Because the current handling of waste is using the Open Dumping Method, the Final Processing Sites/Tempat Penampungan Akhir (TPA) is apart from the many obstacles, the method is proven to be only new to the process of removing waste problems and not dealing with waste problems, there are many cases of accumulation and overload in TPS in TPS as well as a bunch of other problems that always arise nowadays
2. The system for handling waste problems can only be accommodated as much as 30% of the total waste products so that there will always be 70% piles of garbage that accumulate over time and cause bad impacts on city planning and environmental problems in the area
3. As a real alternative solution in dealing with complex situations related to the handling of waste management problems in rural and urban areas around the banks and creeks which are included in handling and Supervision.

TOSS-TMRL Eco Green City Concept is shown in Figure 1. The model for the application of the TOSS-TMRL area where a special place for waste management and processing is carried out directly at the source and production site for producing waste has been implemented in several areas of the Citarum Harum program.

2.3.12. Centralized waste control and monitoring system

Centralized Waste Control and Monitoring System is expected to reduce or even eliminate the transportation of waste to TPS (Temporary Processing Site), TPA (Final Processing Site). TOSS-TMRL based on Internet of Things (IoT) technology designed by Telkom University can be applied to waste management and trash bins. Controls are made automatically and can be monitored remotely using a microcontroller to execute all desired commands to support smart TOSS-TMRL (Sitanggang et al., 2020).

Information is sent by the Smart Trash to the Firebase Real-Time Database (Firebase). Firebase is a database stored in the cloud,

Figure 1: TOSS-TMRL eco green city concept

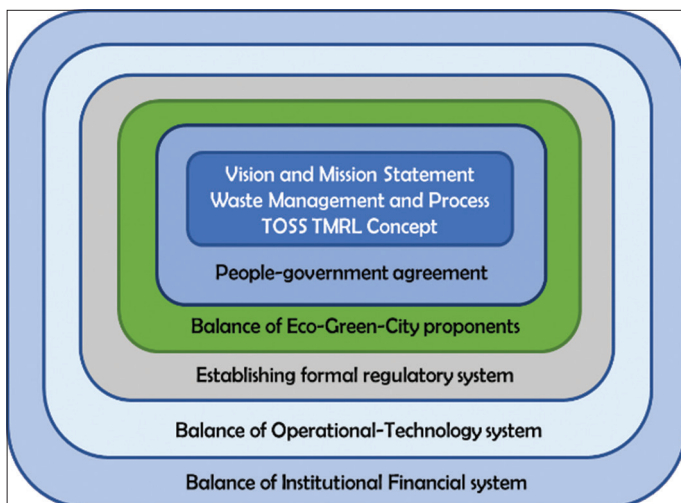

information is stored as JSON and synced in real-time to every connected client. The IoT-based intelligent trash bin is connected to firebase so users will receive the latest data updates from the trash bin automatically. Information on the results of monitoring recycles bins can also be conveyed to management through websites and Android-based applications and can provide early warnings in the event of extreme weather changes, which can affect the landfill that will be processed by GPM.

Centralized Waste Control and Monitoring System with WSN-based IoT which has many sensor nodes can monitor the physical characteristics of the recycle bin (eg temperature, humidity, light, vibration, pressure, etc.). Monitoring information can be distributed via universal platform 2G/3G/4G/GPRS GSM Network Telemetry Data Logger, TCP-IP, Wearable Devices, WiFi, Bluetooth, ZigBee, LoRa, NB-IoT which can send and receive analog and digital data via IoT Hub. WSN is designed to exchange data over the internet network. Sensors can be installed in inaccessible areas but controlled centrally.

Sensors are being used more frequently. In addition to data collecting, the sensor is also in charge of network analysis, correlation, and the fusion of data from both its own sensor and that of other sensor nodes. A WSN is created when numerous sensors work together to jointly monitor a sizable physical environment. The sensor node communicates with other sensors and with the base station (BS) using wi-fi so that it can disseminate data through the IoT Hub for visualization, analysis, and storage systems.

Figure 2 shows the architecture of the centralized waste control and monitoring system. The architecture that is built has the following characteristics:

- Each sensor node works on data acquisition and transfer. The data resulted is sent to the supervisor system, thereby supporting users to find decision-making solutions, such as optimization of resource organization (trash carts/via motorbikes, specific people and machines), with the main task of carrying out cost reductions
- Some sensors are equipped with more powerful computing and communication capabilities to perform extensive processing and data fusion functionality. Such devices perform data transfers between different networks with limited resources
- In system monitoring, Decision Support System (DSS) plays a role to support system administrators. In this system, data collection tools and op-timelines are useful to increase the waste management process optimally.

The control and monitoring system in the form of indicators on the carts and trash bins serves to provide information about the volume of the carts and recycle bins to the waste owner and at the same time to the cleaning staff. Officers can be more effective and efficient in carrying out the task of transporting waste based on information on the identity of the owner of the waste and the volume in the recycle bin. Control and monitoring architecture as shown in Figure 3.

Figures 4 and 5 show a model of a smart recycle bin and garbage cart system that can measure the weight and height of garbage in bins/bins and carts/motorcycles/garbage pickup cars.

Figure 2: The centralized waste control and monitoring system

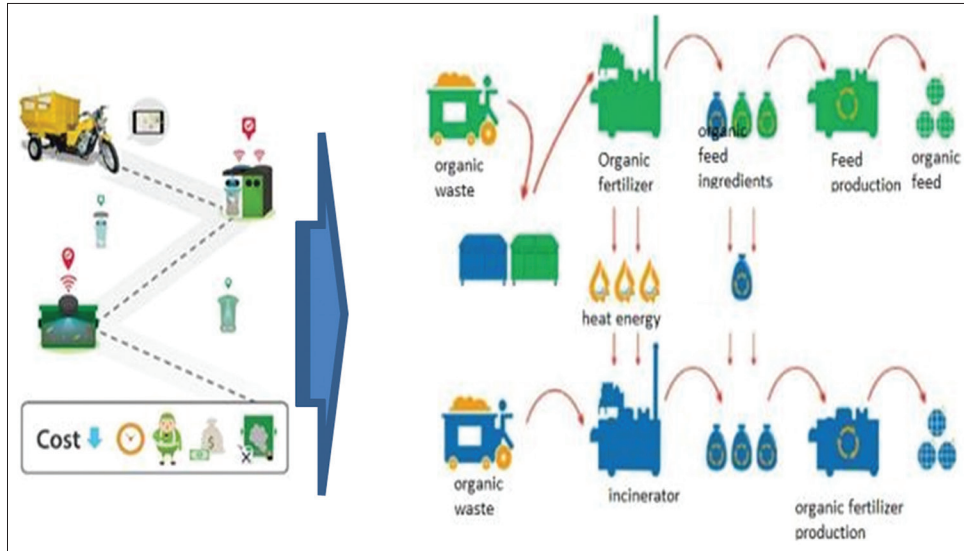

Figure 3: Control and monitoring system TOSS-TMRL

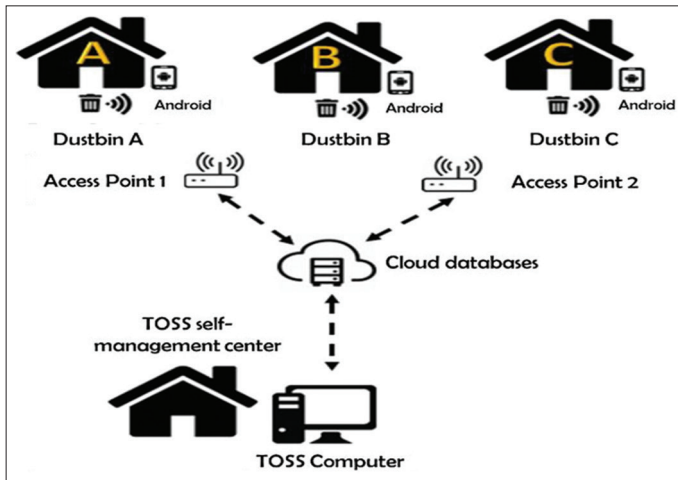
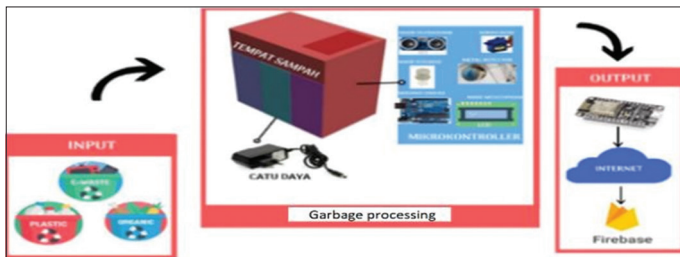

Figure 4: Intelligent trash system architecture



2.4. Research Method

2.4.1. Local waste management study model

The study model for local waste management is carried out with an integrated concept based on the amount of waste obtained from the calculation of material balance, data from research on waste characteristics, and the ability to process TOSS-TMRL waste at Telkom University. The study was conducted on operational technical aspects, financial aspects, and institutional aspects.

- Operational technical aspects

This study covers the TOSS-TMRL waste management system conducted at Telkom University, waste processing raw materials, facilities and infrastructure needed, storage systems and capacities, collection, and transportation of waste from the source to TOSS TMRL. The analysis and evaluation were carried out according to the existing literature, the Ministry of Public Works (2007), the Environment Agency, and related regulations.

- Financial aspects

This study covers the costs required for investment, operation, and maintenance as well as the income generated from the sale of campus TOSS-TMRL products. Then a feasibility assessment is carried out based on investment criteria such as the Internal Rate Return and Benefit/Cost Ratio.

- Institutional aspects

- This study covers the organizational structure and human resource needs of TOSS-TMRL Telkom University.

The system developed is very helpful for cleaners to pick up trash on time, so that areas, buildings, dormitories, canteens, and other infrastructure facilities are kept clean, free from the smell of garbage, and free from disease. Figures 6-8 are models of the IoT-Based Centralized Waste Management Control and Monitoring Network Architecture that can be implemented gradually in several areas up to the Village using the Village Smart Village Network.

Figure 8 shows the infrastructure using the INTRANET/Local Network model, with a Layer 2 switch as the internet that functions for media access to the outside of the infrastructure. This infrastructure is divided into 3 parts:

- The Control Center/Command Center, where the main active devices and the TOSS-TMRL control and monitoring system will be installed.
- The network/Network section is the media access link between

supply, wastewater management, and drainage as well as electricity and communication facilities for TOSS-TMRL Telkom University.

The primary data needed is in the form of existing waste management data on campus which was obtained by interviewing related parties who are responsible for the implementation of waste management and processing as well as direct observations in the field. Secondary data is required in the form of measurement data on the generation, composition, and recycling potential of five of campus waste, as well as data on characteristics of institutional waste sources in Bandung Regency. In addition, data on the description of the campus is also needed including the area and land use, population, geology, and hydrology as well as other supporting facilities such as drinking water supply, wastewater management, and drainages as well as electricity and communication facilities.

3. IMPLEMENTATION RESULTS AND DISCUSSION

3.1. System and Network Architecture Design

The architecture built as shown in Figure 11 consists of three layers, such as a dustbin, WSN on the second layer, and a supervisory system on the third layer.

Each dustbin is connected to a sensor node that provides filling monitoring and can send data captured by the supervisor system, via the IoT Hub. The implementation of the sensor dustbin network is shown in Figure 12. WSN networks are designed to be able to communicate with others, using different devices with standards, such as the IEEE 802.15.4 standard, WiFi, GSM, and GPRS.

The physical architecture consists of three parts:

1. Sensor nodes
 - Its are required for charging monitoring and providing short-range transmission via wi-fi for sensor nodes that are close to deployment distances.
2. Communication modules,
 - It provides long-distance transmission via GSM/GPRS.
3. The IoT Hub
 - It provides storage space and monitoring modules.

Considering different scenarios, the first part generates some profits in an urban area by using Wi-Fi. It allows transmission without the need for a telephone operator subscription. The second part serves as a connector between the sensors and the server via the IoT Hub. GSM/GPRS transmission is used

Figure 9: TOSS TMRL system planning

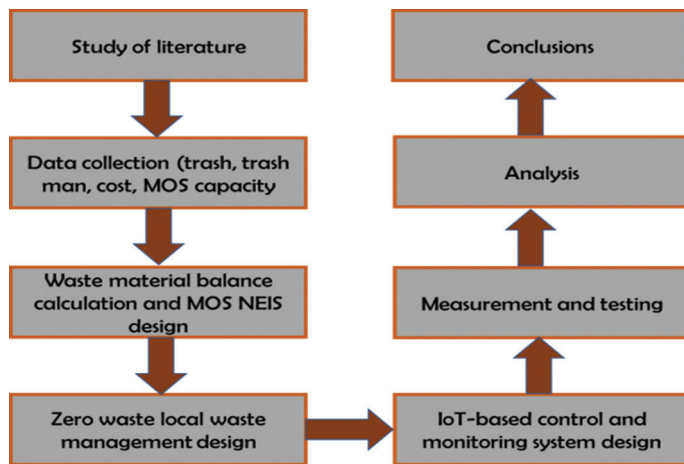

Figure 10: TOSS-TMRL in Telkom university



Figure 11: Internet of Things (IoT) Based Waste Management Architecture Design

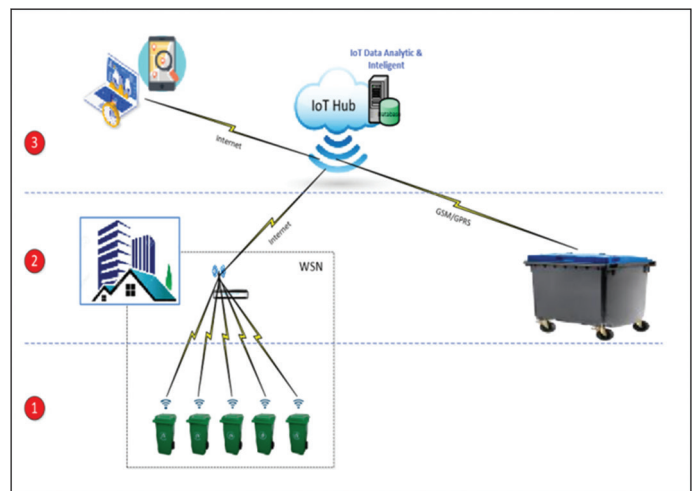
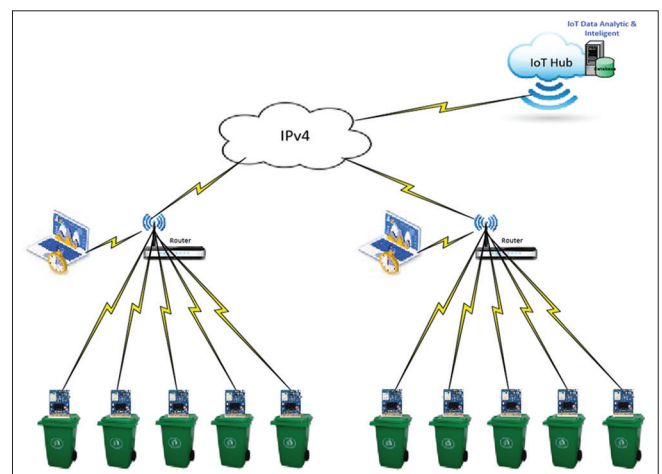

Figure 12: Wireless Sensor Network Architecture



for remoting data transfer, monitoring systems, and detecting errors. In addition, it performs the mechanism for updating the firmware on the sensor nodes and their communication modules. The second part provides benefits in geographic areas with low population density or large areas which hard to reach. The last part is the server used for data storage and DSS. The DSS must be able to work on different operating systems and extract consistent data from the database so that the waste management process becomes effective and efficient.

3.2. Developed WSN Architecture

The architecture can be developed in a typical urban application scenario, where WSN must be installed with different units to set remote monitoring services from each node, as shown in Figure 12.

In this study, a Low Power Area Network (LowPans) is built from many sensor nodes as shown in Figure 13. A Wi-Fi router is used to access the internet on a LowPans network while implementing a delay tolerant network (DTN). The IEEE 802.15.4-compliant CC2420 Transcendent RF is used as a radio module. The MSP430 chip is used as the MCU sensor node, while the IoT Hub/IoT Core is used to manage sensor data retrieval.

Figure 13: Sensor node

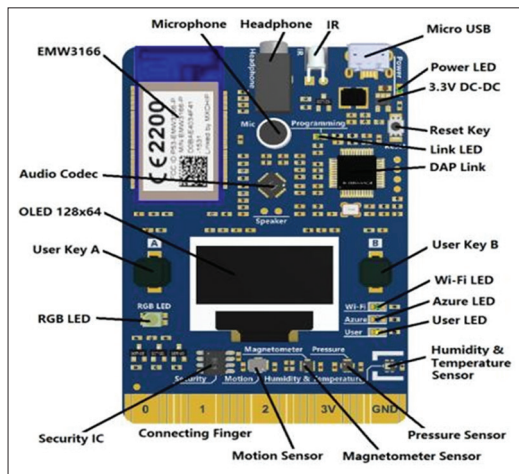

Source: https://www.alibaba.com/product-detail/EMW3166-MXCHIP-IOT-Internet-of-Things_60840097205.html.

The communication mechanism uses IPv4 packets as shown in Figure 14, modified from Microsoft, 2018. When the user communicates with the sensor node, the IPv4 packet is sent to the IoT Hub. Sensor nodes notify servers in the cloud about regularly obtained garbage-fill measurements.

3.3. Developed WSN Architecture

Recently, industrial management systems have improved by implementing various IoT technologies, which enable easy integration of waste detection technologies (sensors, QR codes, AR, imaging, and CCTV) with wireless communications as well as advances in cloud-based databases. The use of various sensors for the automation of waste management has been widely applied and is very popular abroad. The general purpose of this application is to increase the level of automation of the management process, quality of management results, energy efficiency, and other important performances. The technology and environment applied to waste management can be different, therefore it is necessary to choose a type of waste detection technology that can facilitate its implementation. The IoT-based sensor workflow shown in Figure 15 is modified from (Huh et al., 2021) and (Zohari and Zulkefle, 2020) including getting waste data, measuring weight, and determining the type of waste.

The load sensor module uses a microcontroller (MC) with a built-in Wi-Fi module (such as ElectricImp, ESP8266, etc.); with the following specifications:

1. 2.4 GHz WiFi network (with ElectricImp and 5 GHz ESP) within the LSM work zone, the chosen MC allows the transmission of junk heavy data to cloud-based servers S (based on MS Azure and Amazon platforms), where data is stored and processed without hardware elements of external wireless communications
2. The chosen MC has functions for reprogramming and status monitoring, i.e. enabling remote and algorithm changes, coefficient calibration, and other LSM working parameters via wireless Internet.

3.4. TOSS TMRL Governance StartUp

Start-Up in the field of Governance for TOSS TMRL for Telkom University students can be derived from the results of the Study

Figure 14: IoT architecture

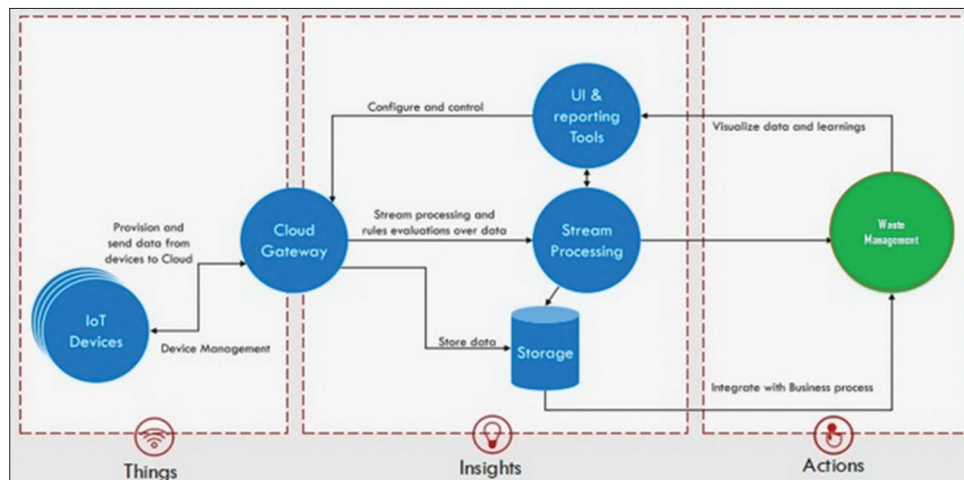
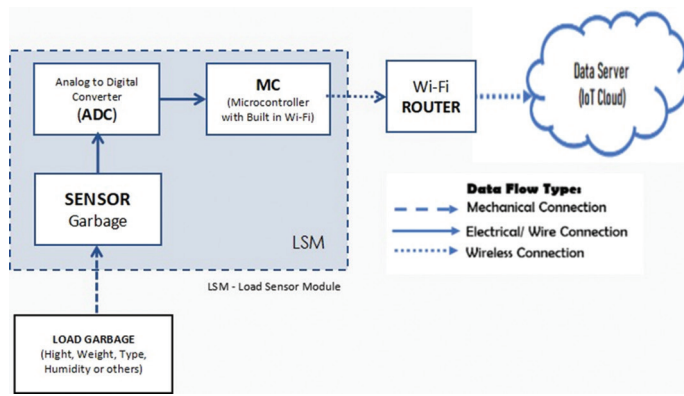

Figure 15: IoT-based sensor diagram

on Management Planning for the Environmentally Friendly Independent Local Waste Treatment System at Telkom University (TOSS-TMRL TEL-U) With Centralized Control Based on the Internet of Things (IoT) Towards a Smart Eco Campus into a variety of POSS (Local Waste Processing Products) based on integrated new renewable energy and green ICT, including:

1. Garbage Bank Application (valuable waste bottles, cans, cardboard, etc.)
2. Organic Fertilizer (solid and liquid)
3. Animal Feed/Pellets
4. Electrical Energy (TOSS waste electricity) has been studied by Putra et al. "Designing a Turbine Inlet Valve Control System in a Waste Power Plant" eProceedings of Engineering, 2018
5. Multipurpose GPM (Smart GPM)
6. Automated Integrated TOSS system and device spare parts (Smart Trash, MOS, non-electrical pumps, power plants, HW/SW applications, etc.)
7. Gallery TOSS TMRL
8. Living Labs Science Techno Park (Educational Tourism - Research)
9. Waste management and processing services, training, and certification

Meanwhile, efforts to develop start-ups and the scope of smart business areas of TOSS-TMRL Governance for Telkom University students are carried out through the development of R and DB with a scheme/pattern of cooperation or partnership.

1. Investment
 - Cooperation in running a waste management business (smart environment) through an attractive investment scheme with a profit-sharing pattern.
2. Franchisee
 - Cooperation in running a waste management business (smart environment) through a franchise scheme. The MoU is enforced followed by a cooperation agreement to agree on a sales plan (a number of outlet units) to be carried out for a certain period and a contract agreement as a short-term execution of the sale and purchase.
3. Joint Operation (JO)
 - Merging with other parties into a new entity called Joint Operation (JO). Each party can protect its interests well. The amount of ownership is negotiated with the record that the

creator continues to play a role in product management and branding,

4. Job Order System
 - Limited cooperation with other parties only for orders received. This collaboration is only limited during the Regional Development process according to the order until the handover. Other parties can act as investors with a profit-sharing scheme.
5. Social Branding
 - Cooperation with various companies and agencies that support the existence and development of smart environmental business products, including the development of the TOSS-TMRL-TPS/TPS 3R (Reduce-Reuse-Recycle) product for wider application in the community.

4. CONCLUSION

Environmental management on the Telkom University campus still allows for improvements, especially related to environmental infrastructure, especially the management and management of campus waste, which can be done by Telkom University in order to get to the Telkom University eco-campus and get the best Green Rating metrics.

With the advantages in the field of ICT technology, the application of the eco-campus at Telkom University is directed to implement various results of environmentally friendly appropriate technology research that has been carried out, specifically waste management and processing because it is closely related to water management issues, renewable energy, and environmental health.

System and network architecture design of Telkom University TOSS-TMRL Management System With Centralized Control Based on the Internet of Things (IoT) Towards Smart ECO Campus are made based on the number of sensor nodes, the number of recycle bins, the number of waste transportation equipment, the number of buildings, the number of areas and the ability of Data Transfer Nodes (DTN) to provide data to servers in the Cloud taken from the recycle bin of every room/building, business area, Star-Ups facility, Small and medium enterprises (UKM), canteen, and dormitory or local area according to the capacity of the Multipurpose Waste Processing Machine available at TOSS-TMRL Campus Telkom University every day so that there is no garbage accumulation in TOSS-TMRL by implementing an IoT-based WSN application that allows users/waste managers to interact with the system via a web browser and android application.

The lesson plan of the TOSS-TMRL management system at Telkom University with Centralized Control Based on IoT towards a Smart ECO Campus can reduce and solve the problem of waste generation. The danger of infection with germs, bacteria, and viruses comes from special bins in shared spaces. In addition, the recycle bin/garbage cart/smart garbage transport vehicle is one of the means to run a program that has been designed to maintain health and cleanliness in the campus environment. With the application of several detection devices as motor drivers, limit switches, and dc motors, one device entity is produced that can work well to help the 3R process of waste, transport, and process waste in the TOSS TMRL area of Telkom University optimally.

Optimization of waste management and processing is complete on-site so that waste is no longer transported by the cleaning service to Garbage Shelter (TPS) and Landfills (TPA) but is utilized so that it can reduce pollution, operational and investment costs and can even function as campus Living Labs and Science Techno Park (Educational Tourism - Research) as one of the efforts to realize a smart eco campus towards the best ranking of Green Metric Telkom University.

For further study, sample testing, measurement, and data collection by utilizing and empowering the TOSS TMRL Management System in integrated activities, services, and time. The control and monitoring network cover area can be used for academic services, specifically for applied practice activities and Digital Solution innovations in existing open spaces and buildings around the School of Applied Sciences (FIT) using WiMax network access and FO Network and WiFi as well as integration with GSM Cellular Lab grants ZTE without interfering with the Telkom University network.

The network model can be developed to support and realize smart campuses, smart environments, smart villages, and digital villages in the Self-management area of the Eco-Friendly Integrated Local Waste Management Center (TOSS-TMRL) of the Citarum Harum program which consists of hundreds of villages so that it is interesting to become a product research area. Applied ICT based on the smart environment in the future.

5. ACKNOWLEDGEMENT

This research is funded by Telkom University through the Decree of the vice chancellor for Research and Student Affairs-Telkom University, No. KWR4-084/PNLT2/PPM/2018 and No. KWR4-136/ABD13/PPM/2018.

REFERENCES

- Badan Standarisasi Nasional. (1995), Spesifikasi Timbulan Sampah Untuk Kota Kecil dan Kota Sedang di Indonesia, Badan Standarisasi Nasional, SNI 19-3983-1995. Indonesia: Badan Standarisasi Nasional.
- Badan Standarisasi Nasional. (2002), Tata Cara Teknik Operasional Pengelolaan Sampah Perkotaan. Badan Standarisasi Nasional, SNI 19-2454-2002. Indonesia: Badan Standarisasi Nasional.
- Bretschger, L., Pittel, K. (2020), Twenty key challenges in environmental and resource economics. *Environmental and Resource Economics*, 77(4), 725-750.
- Ferronato, N., Torretta, V. (2019), Waste mismanagement in developing countries: A review of global issues. *International Journal of Environmental Research and Public Health*, 16(6), 16061060.
- Findler, F., Schönherr, N., Lozano, R., Reider, D., Martinuzzi, A. (2019), The impacts of higher education institutions on sustainable development: A review and conceptualization. *International Journal of Sustainability in Higher Education*, 20(1), 23-38.
- Finlay, J., Massey, J. (2012), Eco-campus: Applying the ecocity model to develop green university and college campuses. *International Journal of Sustainability in Higher Education*, 13(2), 150-165.
- Gandasari, I., Hotimah, O., Miyarsah, M. (2020), Green campus as a concept in creating sustainable campuses. *KnE Social Sciences*, 2020, 1-9.
- Gonigoni. (2020), Available from: <https://gonigoni.id> [Last accessed on 2020 Oct 21].
- Greenmetric, UI. (2017), Available from: <http://greenmetric.ui.ac.id> [Last accessed on 2017 Jan 27].
- Hemidat, S., Oelgemöller, D., Nassour, A., Nelles, M. (2017), Evaluation of key indicators of waste collection using GIS techniques as a planning and control tool for route optimization. *Waste Biomass Valor*, 8, 1533-1554.
- Hermana, J., Irhamah, I., Saptarini, D., Tatas (2018), Designing catchment area for water resources management in ITS campus. *E3S Web of Conferences*, 48, 1-5.
- Huh, J.H., Choi, J.H., Seo, K. (2021), Smart trash bin model design and future for smart city. *Applied Science*, 11, 1-20.
- Jadhav, A.S., Jadhav, V.V., Raut, P.D. (2014), Role of higher education institutions in environmental conservation and sustainable development: A case study of Shivaji University, Maharashtra, India. *Journal of Environmental and Earth Sciences*, 4(5), 30-34.
- Jouhara, H., Czajczyńska, D., Ghazal, H., Krzyżyńska, R., Anguilano, L., Reynolds, A.J., Spencer, N. (2017), Municipal waste management systems for domestic use. *Energy*, 139, 485-506.
- Kusumaningtyas, K., Fithratullah, R., Meluk, C. (2019), The academic community perception about implementation of UI greenmetric-waste management criteria at President University. *Journal of Environmental Engineering and Waste Management*, 4(1), 28-36.
- Lu, Y., Tian, A., Zhang, J., Tang, Y., Shi, P., Tang, Q., Huang, Y. (2020), Physical and chemical properties, pretreatment, and recycling of municipal solid waste incineration fly ash and bottom ash for highway engineering: A literature review. *Advances in Civil Engineering*, 2020, 8886134.
- Maund, K., Gajendran, T., Brewer, G. (2018), Key issues for implementation of environmental planning policy: Construction management practice. *Sustainable*, 10(7), 10072156.
- Microsoft. (2018), Microsoft Azure IoT Reference Architecture, Version 2.1. United States: Microsoft Corporation.
- Putra, F.R.A., Pangaribuan, P., Permana, A.G. (2018), Design of turbine inlet valve control system in waste power plant. *e-Proceeding of Engineering*, 5(3), 4159-4170.
- Short, P. (2009), Responsible environmental action: Its role and status in environmental education and environmental quality. *The Journal of Environmental Education*, 41(1), 7-21.
- Sitanggang, R., Permana, A.G., Darlis, D. (2020), Design and implementation controlling system solid waste and total management information system (TOSS TM) with centered control based on internet of things (IoT). *eProceeding of Applied Science*, 6(1), 646-650.
- Slavoljub, J., Zivkovic, L., Sladjana, A., Dragica, G., Zorica, P.S. (2015), To the environmental responsibility among students through developing their environmental values. *Procedia-Social and Behavioral Sciences*, 171, 317-322.
- Sultana Zerina, S., Roy, S., Akter, N., Mahbuba, S., Nazir, N.B., Das, A., Hossain, N. (2017), Towards an eco-friendly campus design: A place for vibrant activity space and scenic beauty. *International Journal of Scientific and Engineering Research*, 8(11), 1224-1231.
- Suryati, I., Indrawan, I., Alihta, K.N. (2018), Study of carbon dioxide emission inventory from transportation sector at Kualanamu International Airport. *IOP Conference Series: Materials Science and Engineering*, 309, 012023.
- Zega, D.P.K., Permana, A.G., Sunarya, U. (2018), Design of monitoring and controlling incinerator quality application based on IoT. *e-Proceeding of Applied*, 5(3), 1-10.
- Zohari, M.H., Zulkefle, A.S. (2020), Smart garbage monitoring using Internet of Things (IOT). *Journal of Electrical Power and Electronics Systems*, 2(1), 1-5.